

INSTALLATION INSTRUCTIONS

Step Light Linear Recessed 210

GANL-GSLLR5210

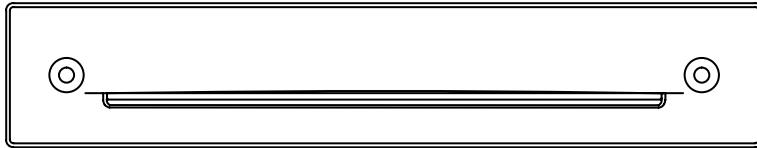

NOTE:

1. Gardens at Night fittings should only be connected to approved Gardens at Night 24VDC or 48VDC Constant Voltage (CV) Power Supplies. FAILURE TO DO SO WILL VOID WARRANTY.
2. Gardens at Night fittings must be wired in parallel and connected in accordance with installation instructions provided (including soldering of cable joins and sealing using Adhesive Lined End Caps). FAILURE TO DO SO WILL VOID WARRANTY.
3. Fittings are polarity sensitive and need to be connected red (+) fitting lead to red (+) incoming and exiting feed cables and black (-) fitting lead to black (-) incoming and exiting feed cables.
4. Do not carry fittings by lead as it may cause damage.
5. Do not connect fittings to constant current (CC) power supplies or AC transformers as this will cause permanent fitting failure and VOID WARRANTY.

CUT-OUT FOR RECESSED INSTALLATION

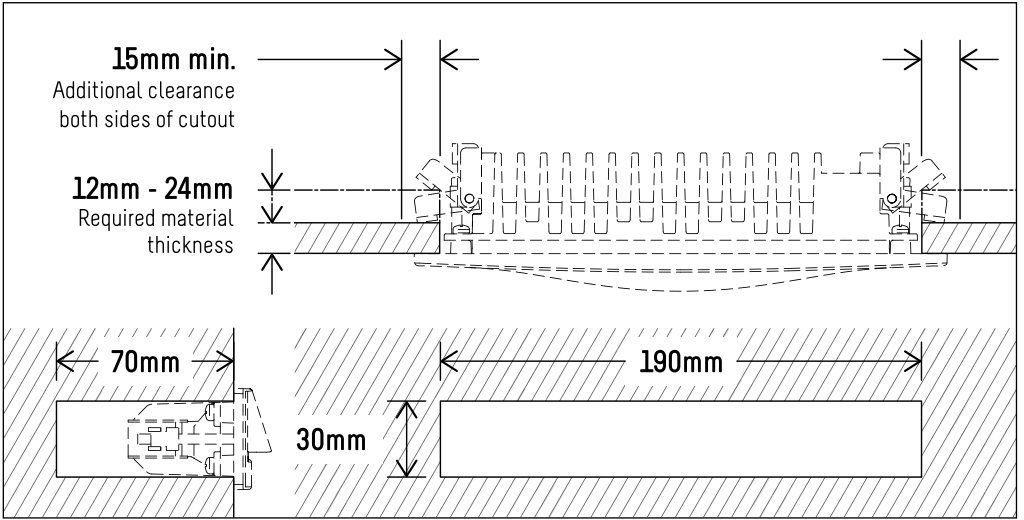

Cut-out for 210mm Step Light is 190mm (W) x 30mm (H) x 70mm (minimum depth) to ensure sufficient space for connector and cable behind light fitting when installed.

FITTING INSTALLATION INSTRUCTIONS

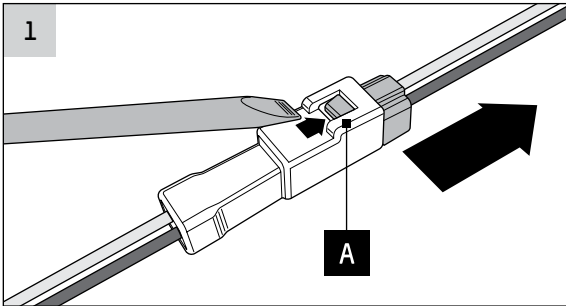

- Separate IP67 connector by pushing on locking tab (A) with small flat blade screwdriver.

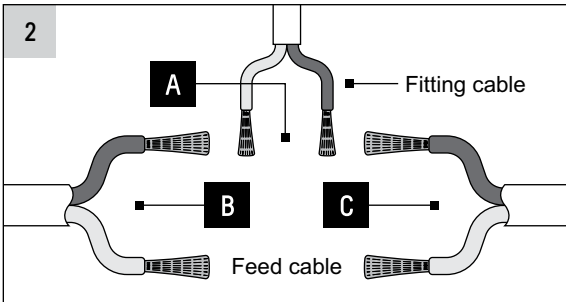

- Cut and remove two solid tinned ends from fitting cable.
- Strip PVC insulation from fitting cable to expose strands (A).
- Cut incoming feed cable from power supply (B).
- Strip PVC insulation to expose copper strands from incoming feed cable (B) and exiting cable (C).

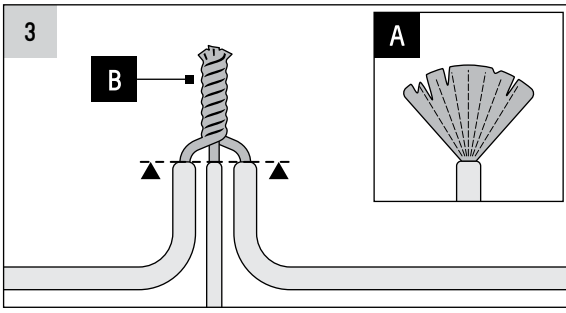

- Fan out all exposed copper strands (A).
- Tightly twist red fitting, feed and exiting cable (B), ensuring shoulders of PVC insulation remain aligned.
- Repeat for black cables.

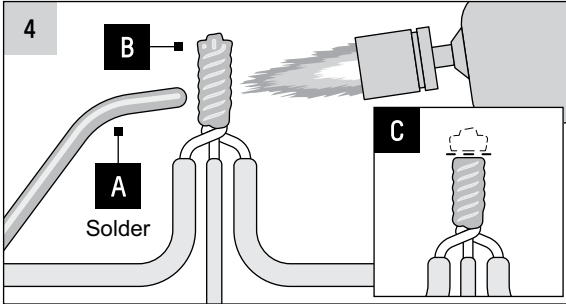

- Heat twisted copper with Butane Gas Torch* and apply solder (A).
- Solder should fully penetrate all strands (B).
- Trim solder with side cutters and carefully remove any sharp edges (C).
- Repeat for other cable join.

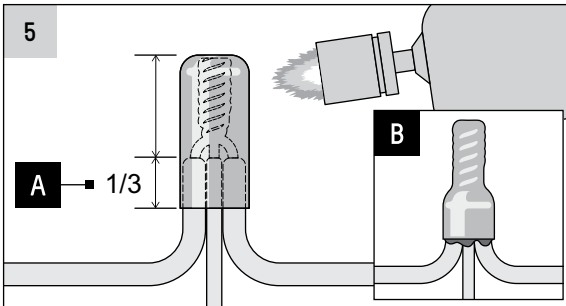

- Place Adhesive Lined End Cap** over soldered joint.
- Ensure 1/3 (minimum) of cap length overlaps PVC insulation (A).
- Apply heat gently to end cap. Cap will collapse and encapsulate the joint (B). Adhesive should be visible from the base of the cap.
- Repeat for other cable join.

FITTING INSTALLATION INSTRUCTIONS – RECESSED

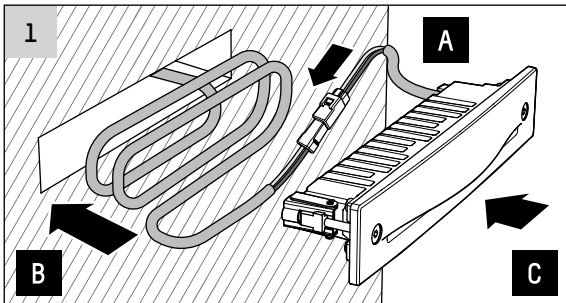

- Reconnect IP67 connector (A).
- Coil cable neatly into cut-out cavity (B).
- Insert fitting into cavity (C).

* Butane Gas Torch and solder available from Gardens at Night.

** Adhesive Lined End Caps are available in various sizes to suit different low voltage cable sizes. Caps should be at least 1/3 larger than join and are available from Gardens at Night.

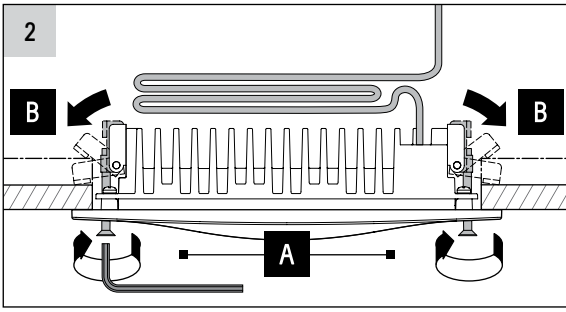

To secure fitting:

- Turn mounting screws clockwise with Hex Tool (included) (A). Ensure both sides are tightened evenly.
- Fixing arms will rotate outwards to hold fitting in cavity (B).

DO NOT OVERTIGHTEN SCREWS AS THIS MAY RESULT IN DAMAGE TO FIXING MECHANISM.

FITTING INSTALLATION INSTRUCTIONS – CONCRETE

INSTALLATION CANISTER REQUIRED FOR CONCRETE – PART NO. GSSLRC5210 - CANISTER (SOLD SEPARATELY)

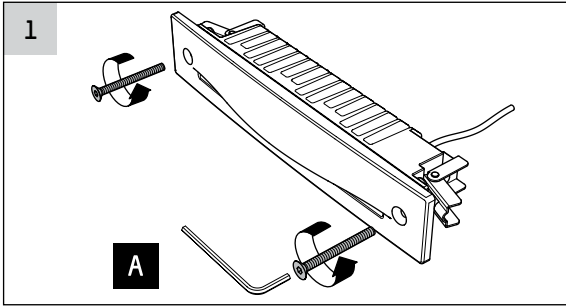

- Turn two mounting screws anti-clockwise with hex tool (included) and fully remove from light fitting (A).
- Keep two mounting screws in safe place for later use.

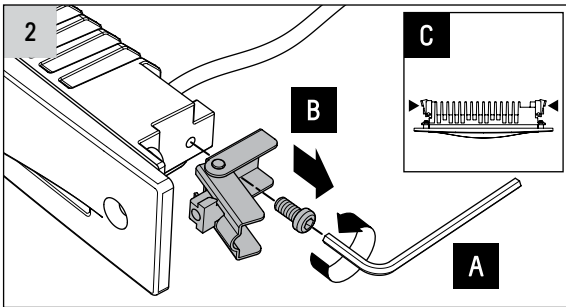

To remove fixing arm assemblies:

- Use Hex Tool (included) to remove fixing arm mount screw from light fitting (A).
- Remove fixing arm assembly (B).
- Repeat for other fixing arm assembly (C).

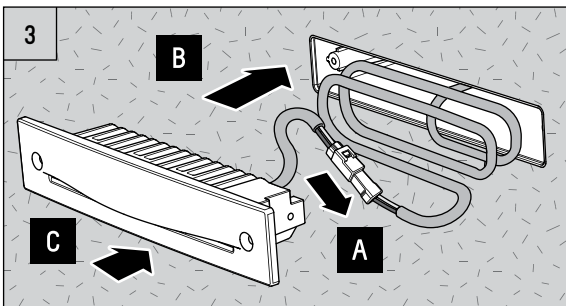

- Reconnect IP67 connector (A).
- Coil cable neatly into Canister (B).
- Insert fitting into Canister (C).

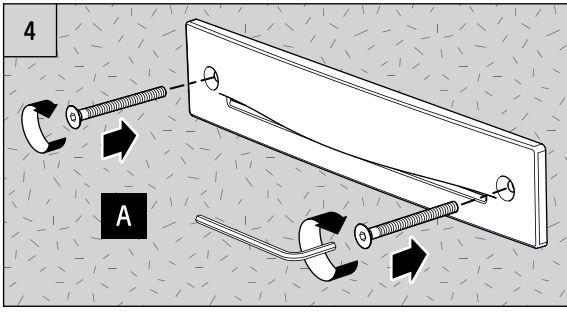

To secure fitting into Canister:

- Insert two mounting screws through holes in fitting and locate into mounting points in Canister.
- Tighten mounting screws with Hex Tool (included) (A). Ensure both sides are tightened evenly.

**DO NOT OVERTIGHTEN SCREWS
AS THIS MAY RESULT IN DAMAGE
TO INSTALLATION CANISTER.**

WARRANTY STATEMENT

Gardens at Night warrants that, subject to the exclusions and limitations below, all products will be free from defects in materials and workmanship for a minimum period of 12 months from the date of purchase or as stated on the Product Information sheet.

If a defect appears in a Product before the end of the Warranty Period, and Gardens at Night finds the Product to be defective in materials or workmanship, Gardens at Night will, in its sole discretion, either:

- (a) repair the Product or the defective part of the Product free of charge; or
- (b) have the Product or the defective part of the Product repaired by a qualified repairer free of charge; or
- (c) replace the Product.

Gardens at Night reserves the right to replace defective parts of the Products with parts and components of similar quality, grade and composition where an identical part or component is not available. Products presented for repair may be replaced by refurbished Product parts of the same type rather than being repaired. Refurbished parts may be used to repair the Products.

WARRANTY CLAIMS

1. If a fault covered by this warranty occurs, the customer must first contact Gardens at Night on the contact details below, or the trader from whom the Product was purchased.
2. Any warranty claim must be accompanied by:
 - (a) proof of purchase;
 - (b) full details of the alleged defect; and
 - (c) any other appropriate documentation.
3. The customer must make the Product available to Gardens at Night or its authorised repair agent for inspection and testing. If such inspection and testing finds no defect in the Product, the customer must pay Gardens at Night's usual costs of service work and testing.
4. The customer must bear the cost of the transport of the Product to and from Gardens at Night or its authorised repair agent, and all insurance of the Product.

EXCLUSIONS

This warranty will not apply where:

- (a) the Product has not been installed in accordance with the installation instructions provided with the Product;
- (b) the Product has been repaired, altered or modified by someone other than Gardens at Night or its authorised agent;
- (c) the alleged defect in the Product is within acceptable industry variances;
- (d) Gardens at Night cannot establish any fault in the Product after testing and inspection;
- (e) the product has been used for a purpose other than that for which it was designed and manufactured;
- (f) the defect in the Product has arisen due to the customer's failure to properly use, service or maintain the Product in accordance with any instructions or user manuals that are supplied with the Product;

- (g) the Product has been subject to abnormal conditions, including environment, temperature, water, fire, humidity or similar;
- (h) the defect has arisen due to abuse, misuse, neglect or accident;
- (i) the damage occurred in transit;
- (j) the damage is due to power surges.

The warranty does not extend to:

- (a) damage or defects caused by normal wear and tear; or
- (b) surface rust.

LIMITATIONS

Gardens at Night makes no express warranties or representations other than set out in this warranty.

Except to the extent required by the Australian Consumer Law, the repair of the Product or part of the Product is the absolute limit of Gardens at Night's liability under this express warranty.

Our goods come with guarantees that cannot be excluded under the Australian Consumer Law. You are entitled to a replacement or refund for a major failure and for compensation for any other reasonably foreseeable loss or damage.

You are also entitled to have the goods repaired or replaced if the goods fail to be of acceptable quality and the failure does not amount to a major failure.

Gardens at Night provides the warranty in relation to any Gardens at Night branded exterior and landscape lighting Product.

The benefits of this warranty are in addition to any rights and remedies imposed by Australian State and Federal legislation that cannot be excluded. Nothing in this warranty is to be interpreted as excluding, restricting or modifying any State or Federal legislation applicable to the supply of goods and services which cannot be excluded, restricted or modified.

www.gan.com.au

MELBOURNE
1316 Malvern Road
Malvern VIC 3144
T 03 9824 4937 E vic@gan.com.au

SYDNEY
88 Alexander Street
Crows Nest NSW 2065
T 02 9439 9155 E nsw@gan.com.au



E4635