

INSTALLATION INSTRUCTIONS

Neon Side Flex Light – Small GANL-GLNSF6x12-XXX

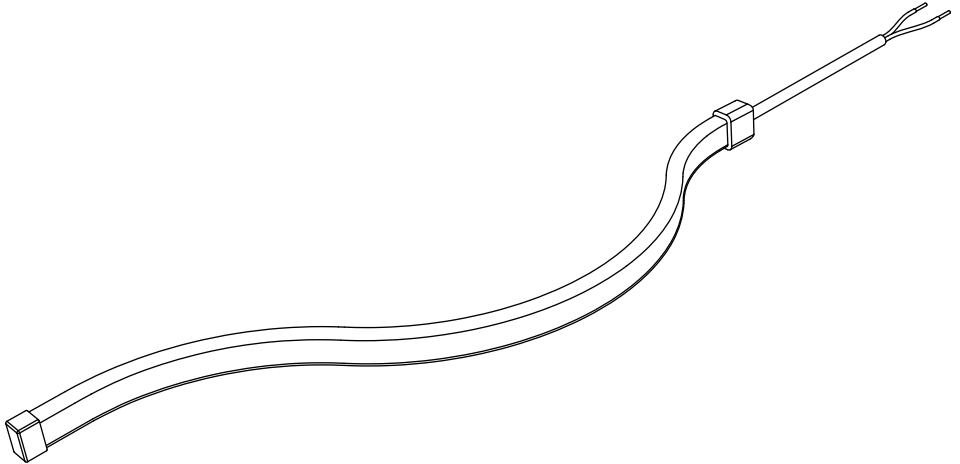

NOTE:

1. Gardens at Night fittings should only be connected to approved Gardens at Night 24VDC Constant Voltage (CV) Power Supplies. FAILURE TO DO SO WILL VOID WARRANTY.
2. Gardens at Night fittings must be wired in parallel and connected in accordance with installation instructions provided (including soldering of cable joins and sealing using Adhesive Lined End Caps). FAILURE TO DO SO WILL VOID WARRANTY.
3. Fittings are polarity sensitive and need to be connected positive (+) fitting lead to positive (+) incoming and exiting feed cables and negative (-) fitting lead to negative (-) incoming and exiting feed cables.
4. Do not carry fittings by lead as it may cause damage.
5. Do not connect fittings to constant current (CC) power supplies or AC transformers as this will cause permanent fitting failure and VOID WARRANTY.

FITTING KIT - PARTS SUMMARY

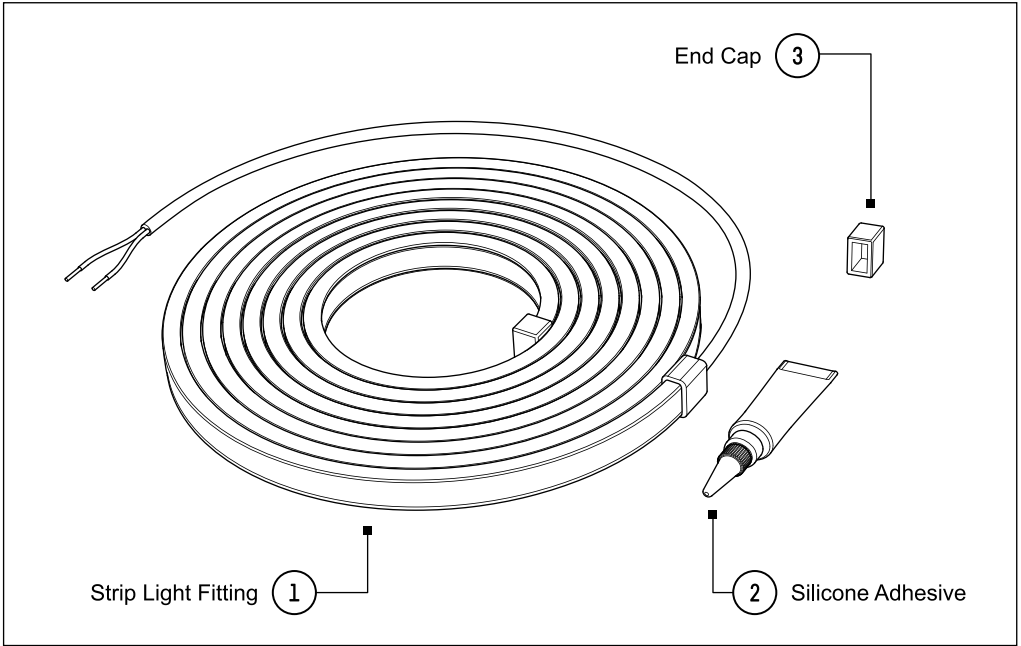

FITTING KIT - PROPER HANDLING

DO NOT illuminate Strip Light Fitting while coiled as this may cause damage.

Strip Light is designed to bend in a **SIDEWAYS DIRECTION ONLY** (at 90° to light output)

Ensure the following handling instructions are followed to avoid damage.

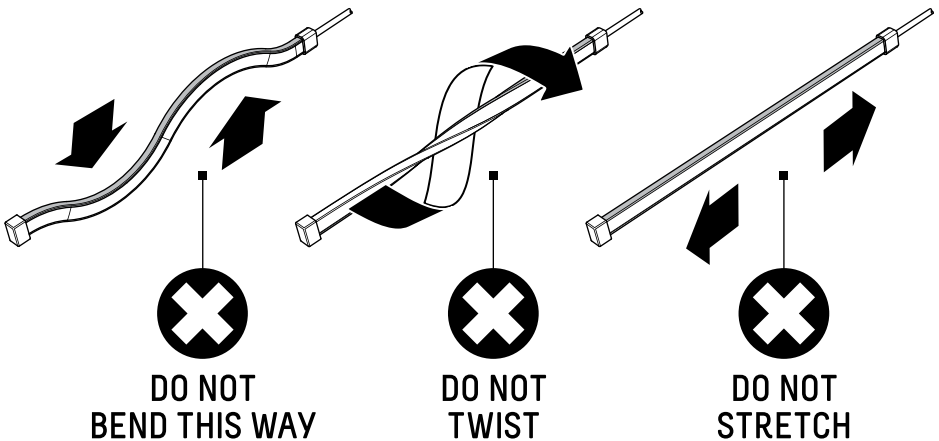

FITTING INSTALLATION INSTRUCTIONS – CUTTING TO LENGTH

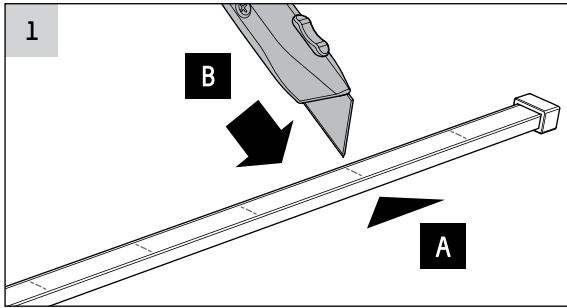

- Locate cut marks printed on side of Strip Light. Find mark best suited to desired length (A).
- Using a sharp utility knife or heavy duty shears make a straight cut through marked mark to trim Strip Light to desired length (B). Take care not to pull internal wiring when cutting.

ONLY CUT AT MARKED POINTS WITH A CLEAN, STRAIGHT CUT TO AVOID DAMAGING STRIP LIGHT.

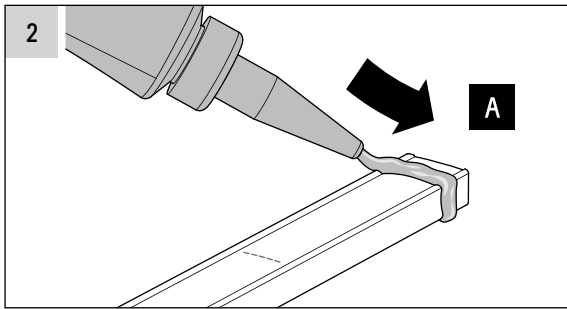

To apply Silicone Adhesive:

- In a well ventilated area, apply a continuous bead of Silicone Adhesive (supplied) around all four sides of Strip Light near cut end (A).

REFER TO ADHESIVE SAFETY INSTRUCTIONS BELOW.

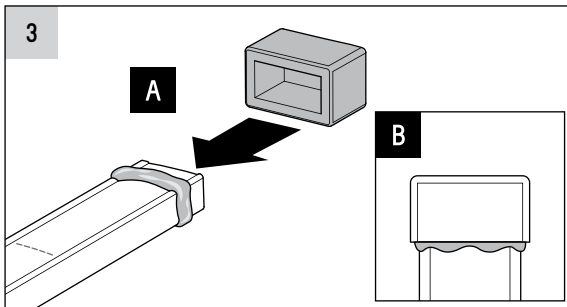

To assemble End Cap:

- Push End Cap over cut end of Strip Light until it is fully engaged (A).
- Check Silicone Adhesive is visible around the base of End Cap to ensure fitting is fully sealed (B). Apply additional Silicone Adhesive if required.
- Set Strip Light aside until Silicone Adhesive is fully cured. Cure time 10 minutes.

CAUTION – SILICONE ADHESIVE SAFETY INSTRUCTIONS



In case of contact, flush eye with water for 15 minutes. Call physician. Sealant may release acetic acid during cure. Avoid prolonged skin contact.
KEEP OUT OF REACH OF CHILDREN. MADE IN CHINA.

FITTING INSTALLATION INSTRUCTIONS – CONNECTION

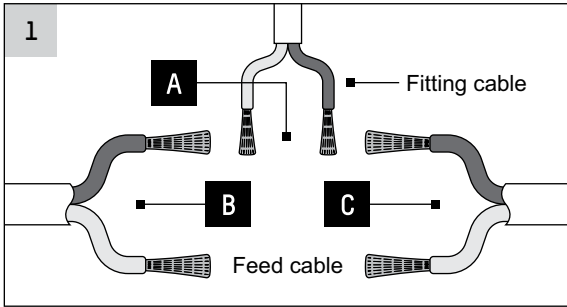

- Cut and remove two solid tinned ends from fitting cable.
- Strip PVC insulation from fitting cable to expose strands (A).
- Cut incoming feed cable from power supply (B).
- Strip PVC insulation to expose copper strands from incoming feed cable (B) and exiting cable (C).

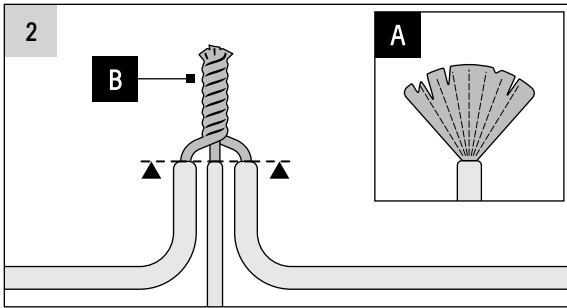

- Fan out all exposed copper strands (A).
- Tightly twist red fitting, feed and exiting cable (B), ensuring shoulders of PVC insulation remain aligned.
- Repeat for black cables.

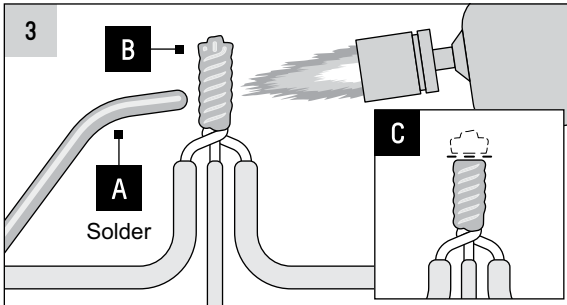

- Heat twisted copper with Butane Gas Torch* and apply solder (A).
- Solder should fully penetrate all strands (B).
- Trim solder with side cutters and carefully remove any sharp edges (C).
- Repeat for other cable join.

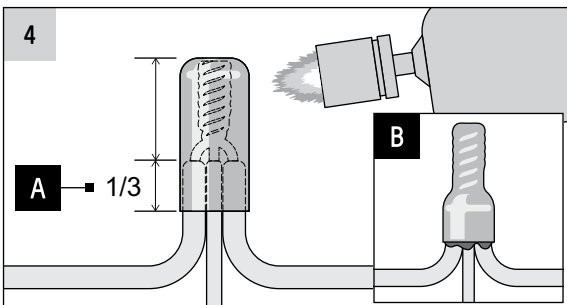

- Place Adhesive Lined End Cap** over soldered joint.
- Ensure 1/3 (minimum) of cap length overlaps PVC insulation (A).
- Apply heat gently to end cap. Cap will collapse and encapsulate the joint (B). Adhesive should be visible from the base of the cap.
- Repeat for other cable join.

* Butane Gas Torch and solder available from Gardens at Night.

** Adhesive Lined End Caps are available in various sizes to suit different low voltage cable sizes. Caps should be at least 1/3 larger than joint and are available from Gardens at Night.

FITTING INSTALLATION INSTRUCTIONS – MOUNT CHANNEL

MOUNT CHANNEL REQUIRED – GANL-GLNSF6x12-Channel-1m (SOLD SEPARATELY)

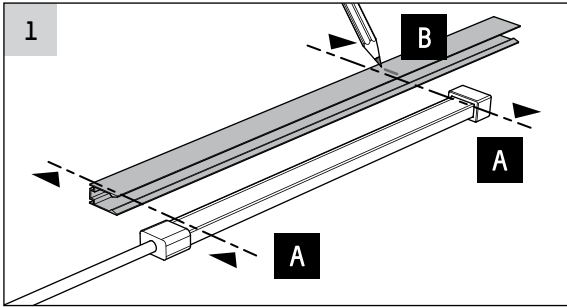

To trim Mount Channel to correct length:

- Carefully measure Strip Light length between inside faces of end caps (A). **END CAPS DO NOT FIT INSIDE MOUNT CHANNEL.**
- Mark and cut Mount Channel to desired length (B).
- Mount Channel is available in 1m sections. For longer installations multiple sections of Mount Channel will be required.

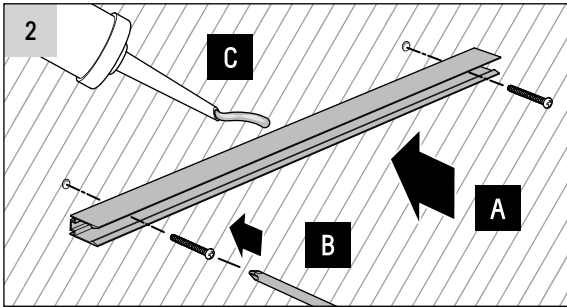

To attach Mount Channel:

- Securely attach Mount Channel/s (A) using appropriate fasteners (B) or adhesive (C) for substrate material and construction.

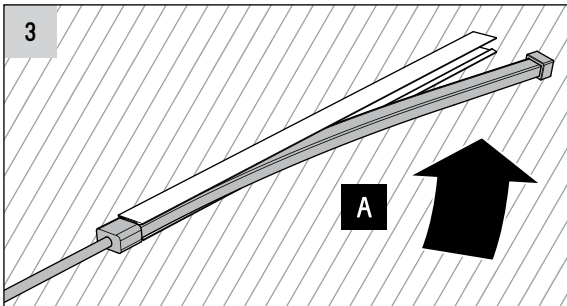

To assemble Strip Light into Mount Channel:

- Carefully uncoil Strip Light.
- Ensure lens side of Strip Light is facing outwards.
- Starting at one end only, insert Strip Light into Mount Channel opening by **HAND ONLY**. Carefully work along length to insert entire Strip Light into Mount Channel (A).

TAKE CARE TO FOLLOW “PROPER HANDLING INSTRUCTIONS” DURING INSTALLATION TO AVOID DAMAGING STRIP LIGHT.

WARRANTY STATEMENT

SERRATA GROUP PTY LTD - ABN 35 131 274 176
Gardens at Night is a business of Serrata Group.

Serrata Group Pty Ltd warrants that, subject to the exclusions and limitations below, all Gardens at Night products will be free from defects in materials and workmanship for a minimum period of 12 months from the date of purchase or as stated on the Product Information sheet.

If a defect appears in a Product before the end of the Warranty Period, and Serrata Group Pty Ltd finds the Product to be defective in materials or workmanship, Serrata Group Pty Ltd will, in its sole discretion, either:

- (a) repair the Product or the defective part of the Product free of charge; or
- (b) cause the Product or the defective part of the Product to be repaired by a qualified repairer free of charge; or
- (c) replace the Product.

Serrata Group Pty Ltd reserves the right to replace defective parts of the Products with parts and components of similar quality, grade and composition where an identical part or component is not available. Products presented for repair may be replaced by refurbished Product parts of the same type rather than being repaired. Refurbished parts may be used to repair the Products.

WARRANTY CLAIMS

1. If a fault covered by this warranty occurs, the customer must first contact Serrata Group Pty Ltd on the contact details below, or the trader from whom the Product was purchased.
2. Any warranty claim must be accompanied by:
 - (a) proof of purchase;
 - (b) full details of the alleged defect; and
 - (c) any other appropriate documentation.
3. The customer must make the Product available to Serrata Group Pty Ltd or its authorised repair agent for inspection and testing. If such inspection and testing finds no defect in the Product, the customer must pay Serrata Group Pty Ltd's usual costs of service work and testing.
4. The customer must bear the cost of the transport of the Product to and from Serrata Group Pty Ltd or its authorised repair agent, and all insurance of the Product.

EXCLUSIONS

This warranty will not apply where:

- (a) the Product has been installed, repaired, altered or modified by someone other than Serrata Group Pty Ltd or its authorised agent;
- (b) the alleged defect in the Product is within acceptable industry variances;
- (c) Serrata Group Pty Ltd cannot establish any fault in the Product after testing and inspection;
- (d) the Product has been used other than for the purpose for which it was designed and manufactured;

- (e) the defect in the Product has arisen due to the customer's failure to properly use, service or maintain the Product in accordance with any instructions or user manuals that are supplied with the Product;
- (f) the Product has been subject to abnormal conditions, including environment, temperature, water, fire, humidity or similar;
- (g) the defect has arisen due to abuse, misuse, neglect or accident
- (h) the damage occurred in transit;
- (i) the damage is due to power surges.

The warranty does not extend to:

- (a) damage or defects caused by normal wear and tear; or
- (b) surface rust.

LIMITATIONS

Serrata Group Pty Ltd makes no express warranties or representations other than set out in this warranty.

Except to the extent required by the Australian Consumer Law, the repair of the Product or part of the Product is the absolute limit of Serrata Group Pty Ltd's liability under this express warranty.

Our goods come with guarantees that cannot be excluded under the Australian Consumer Law. You are entitled to a replacement or refund for a major failure and for compensation for any other reasonably foreseeable loss or damage. You are also entitled to have the goods repaired or replaced if the goods fail to be of acceptable quality and the failure does not amount to a major failure.

Serrata Group Pty Ltd provides the warranty in relation to any Gardens at Night branded exterior and landscape lighting Product.

The benefits of this warranty are in addition to any rights and remedies imposed by Australian State and Federal legislation that cannot be excluded. Nothing in this warranty is to be interpreted as excluding, restricting or modifying any State or Federal legislation applicable to the supply of goods and services which cannot be excluded, restricted or modified.

gardens at night
■ ■ ■ ■ professional lightscaping

For information on Gardens at Night products, local distributor and contact information visit our website.

www.gan.com.au

RoHS  